



 **Doofor**  
ROCK DRILLS

# DOOFOR INC. THE COMPANY

Doofoor Inc. is a company designing and manufacturing hydraulic rock drills, original spare parts, and supporting components, such as drilling feed system components and rock drill carriage plates. A hydraulic rock drill is a key component of any drilling equipment. Doofoor offers drilling technology of the highest quality to ensure the overall functionality and successful operation of these hydraulic drilling devices.

**Our unique rock drills are designed to endure the most demanding environments** and maintain superior performance in extreme working conditions. As a pioneer in the drilling industry, we have successfully integrated valuable industry knowhow into our products to combine drilling speed, energy efficiency and durability.

## Enhance your drilling solution with Doofoor rock drills

Doofoor has been in the industry since 1993. This means that the needs of original drilling equipment manufacturers are our top priority. We strive for long term partnerships in building competitive drilling equipment together with our clients.

### **Our highly skilled workforce and subcontracting network ensures good lead times and flexibility.**

Doofoor works closely with customers and end-users in finding the most durable and economical solutions.

As a trusted Nordic provider, Doofoor offers spare parts availability, maintenance, training, fast-delivery service, as well as ongoing technical and commercial support. Doofoor also offers tailored solutions to meet the specific requirements of your drill rig.

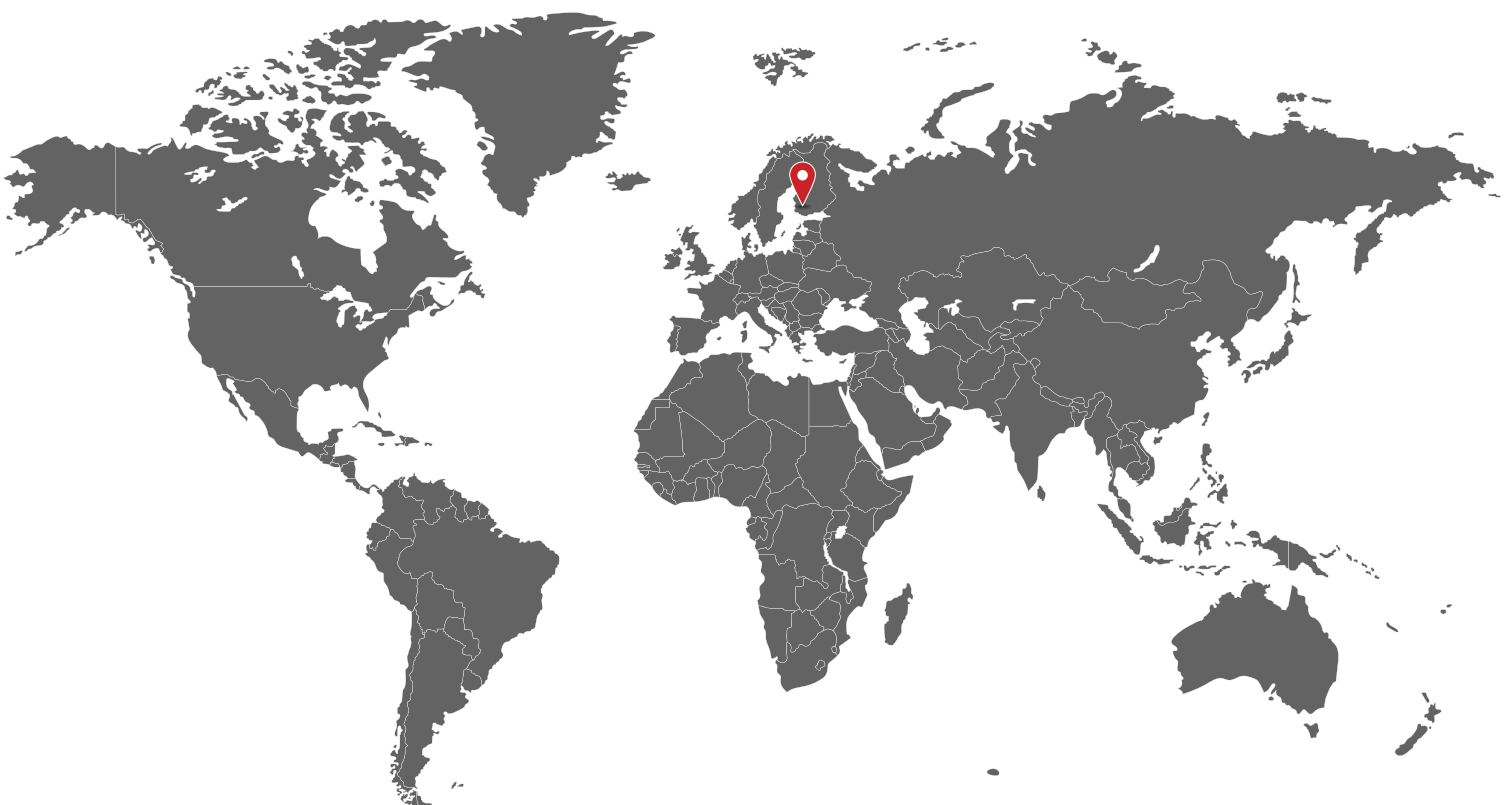

## Trustable production in a modern workshop

Our purpose-built premises in Nokia, Finland, and lean production methods ensure timely delivery of necessary components. We test run every product before delivery to guarantee quality. Our rock drills offer straight holes, good drill tool economy, easy maintenance, adequate drilling speed, and energy efficiency. They are compact, universal, and can be installed in various drilling platforms.

**Competitive Doofor rock drills use the latest technology and components of the highest quality which offer multiple benefits.**

- Straight holes
- Good drill tool economy
- Easy maintenance
- Adequate drilling speed
- Energy efficiency

Doofor high-performance hydraulic rock drills are compact, universal and can be installed in any drilling platform, including hydraulic drill rigs, drill jumbos, bolting and soil nailing equipment, probe drilling and tap hole drilling machines. Customizable Doofor solutions provide freedom for boom structure.

In addition to rock drills, Doofor offers aluminum profiles and hydraulic feed system component kits for machine building professionals.

## Privately owned dedication.

**Doofor is a privately owned family business** that values customer service. Our goal is to make our customers successful by providing the latest drilling technology and allowing them to focus on other aspects of hydraulic drilling equipment design and manufacture.



## FROM FINLAND WORLDWIDE WITH DEDICATION

Unique Doofor drills are known as powerful, reliable, and durable worldwide. We ship to all continents and base our business on long term customer partnerships. We specialize solely on the development of hydraulic rock drills.

**Your success is our business.**

# DF430X HIGH-PERFORMANCE HYDRAULIC ROCK DRILL



Doofor DF430X is a lightweight, high-frequency hydraulic rock drill designed for use in general excavations, quarrying and bolting operations. Flushing media can be air or water. This rock drill has a female hexagonal chuck. Simple design allows for easy serviceability.

This model can be used with a Doofor original drill feed system component kit.

**CIVIL ENGINEERING AND SURFACE**

## TECHNICAL SPECIFICATIONS

### DOOFOR DF430X DRIFTER

NOMINAL POWER CLASS		5 kW	6.7 hp
DRILL HOLE SIZE <sup>4)</sup>		41 mm	1 3/5"
PERCUSSION FLOW		45 l/min	12 gpm
PERCUSSION PRESSURE		120 bar	1740 psi
ROTATION MOTOR MAXIMUM FLOW <sup>1)</sup>	12.5cc	25 l/min	6.6 gpm
	20cc	25 l/min	6.6 gpm
	32cc	25 l/min	6.6 gpm
	40cc	25 l/min	6.6 gpm
ROTATION TORQUE <sup>1)</sup>	12.5cc	64 Nm	47 lb-ft
	20cc	97 Nm	71 lb-ft
	32cc	158 Nm	116 lb-ft
	40cc	194 Nm	143 lb-ft
ROTATION PRESSURE MAXIMUM		140 bar	2031 psi
ROTATION SPEED MAXIMUM <sup>2)</sup>	12.5cc	300 rpm	
	20cc	300 rpm	
	32cc	227 rpm	
	40cc	180 rpm	
LUBRICATION	Air-oil mist	125-200 g/h	4.9-78 fl oz/h (1.4-2.3 dl/h)
LUBRICATION PRESSURE		4-7 bar	58-101 psi
LUBRICATION AIR FLOW		200-300 l/min	53-79 gpm
FLUSHING AIR PRESSURE <sup>3)</sup>		5-8 bar	73-116 psi
FLUSHING AIR FLOW <sup>3)</sup>		700-1200 l/min	185-317 gpm
FLUSHING WATER PRESSURE <sup>3)</sup>		4-12 bar	58-174 psi
FLUSHING WATER FLOW <sup>3)</sup>		15-30 l/min	4-8 gpm
RECOMMENDED MAXIMUM FEED FORCE		3.7 kN	830 lbf
WEIGHT		41 kg	90 lb
SHANK SIZE		108mm [4 1/4"] * 22mm [7/8"] or 25mm [1"]	

<sup>1)</sup> Intermittent value.

<sup>2)</sup> Continuous value. Maximum recommended speed 300 rpm.

<sup>3)</sup> Actual values vary according to drilling conditions and equipment.

<sup>4)</sup> Maximum drill hole size in normal drilling applications.

# DIMENSIONS

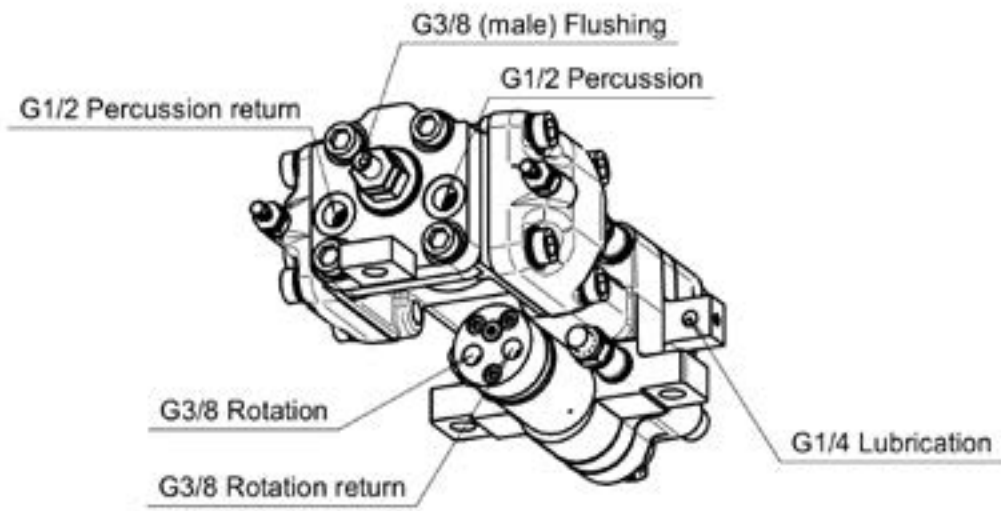
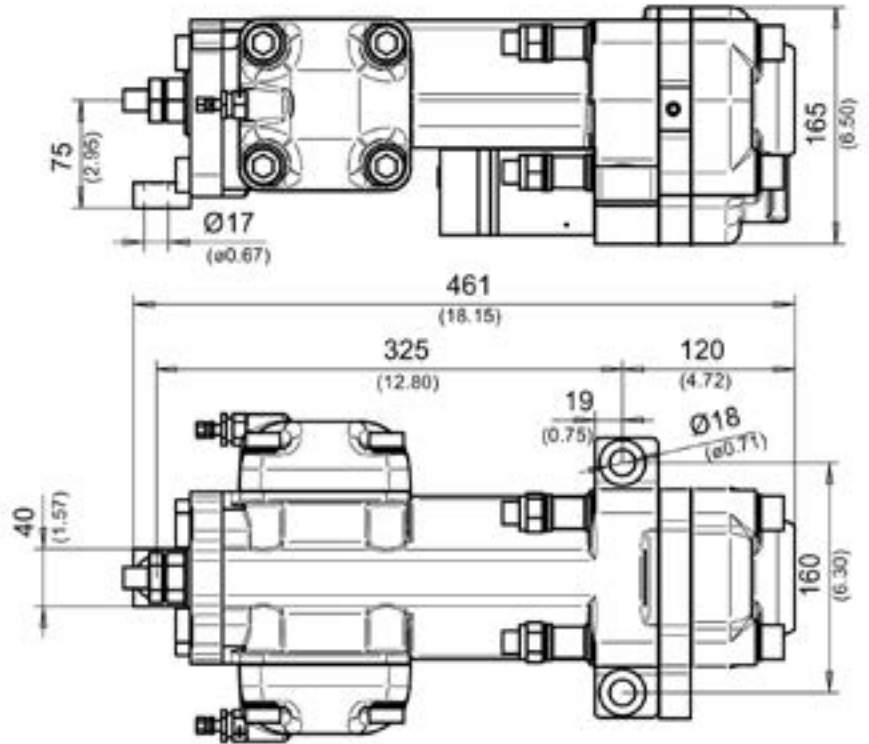
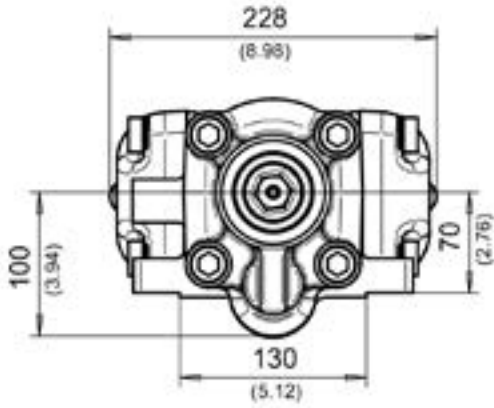

Doofor DF430X has alternative models: Doofor DF430S with a male shank adapter and light piston models Doofor DF420X and Doofor DF410X.



# DF430S

## HIGH-PERFORMANCE HYDRAULIC ROCK DRILL

Doofer DF430S is lightweight, high-frequency rock drills designed for use in general excavations, quarrying and bolting.

DF430S uses R25 or R28 male shank adapter with air or water flushing. The rock drill is equipped with a separate flushing box. Doofer DF430S is easy to maintain due to compact, modular design.

DF430S can be used with a Doofer original drill feed system component kit.



**CIVIL ENGINEERING, UNDERGROUND AND SURFACE**

### TECHNICAL SPECIFICATIONS

#### DOOFER DF430S DRIFTER

NOMINAL POWER CLASS		5 kW	6.7 hp
DRILL HOLE SIZE <sup>4)</sup>		41 mm	1 3/5"
PERCUSSION FLOW		45 l/min	12 gpm
PERCUSSION PRESSURE		120 bar	1740 psi
ROTATION MOTOR MAXIMUM FLOW <sup>1)</sup>	12.5cc	25 l/min	6.6 gpm
	20cc	25 l/min	6.6 gpm
	32cc	25 l/min	6.6 gpm
	40cc	25 l/min	6.6 gpm
ROTATION TORQUE <sup>1)</sup>	12.5cc	64 Nm	47 lb-ft
	20cc	97 Nm	71 lb-ft
	32cc	158 Nm	116 lb-ft
	40cc	194 Nm	143 lb-ft
ROTATION PRESSURE MAXIMUM		140 bar	2031 psi
ROTATION SPEED MAXIMUM <sup>2)</sup>	12.5cc	300 rpm	
	20cc	300 rpm	
	32cc	227 rpm	
	40cc	180 rpm	
LUBRICATION	Air-oil mist	125-200 g/h	4.9-7.8 fl oz/h (1.4-2.3 dl/h)
LUBRICATION PRESSURE		4-7 bar	58-101 psi
LUBRICATION AIR FLOW		200-300 l/min	53-79 gpm
FLUSHING AIR PRESSURE <sup>3)</sup>		5-8 bar	73-116 psi
FLUSHING AIR FLOW <sup>3)</sup>		700-1200 l/min	185-317 gpm
FLUSHING WATER PRESSURE <sup>3)</sup>		4-12 bar	58-174 psi
FLUSHING WATER FLOW <sup>3)</sup>		15-30 l/min	4-8 gpm
RECOMMENDED MAXIMUM FEED FORCE		3.7 kN	830 lbf
WEIGHT		50 kg	110 lb
SHANK SIZE		Male R25, R28	

<sup>1)</sup> Intermittent value.

<sup>2)</sup> Continuous value. Maximum recommended speed 300 rpm.

<sup>3)</sup> Actual values vary according to drilling conditions and equipment.

<sup>4)</sup> Maximum drill hole size in normal drilling applications.

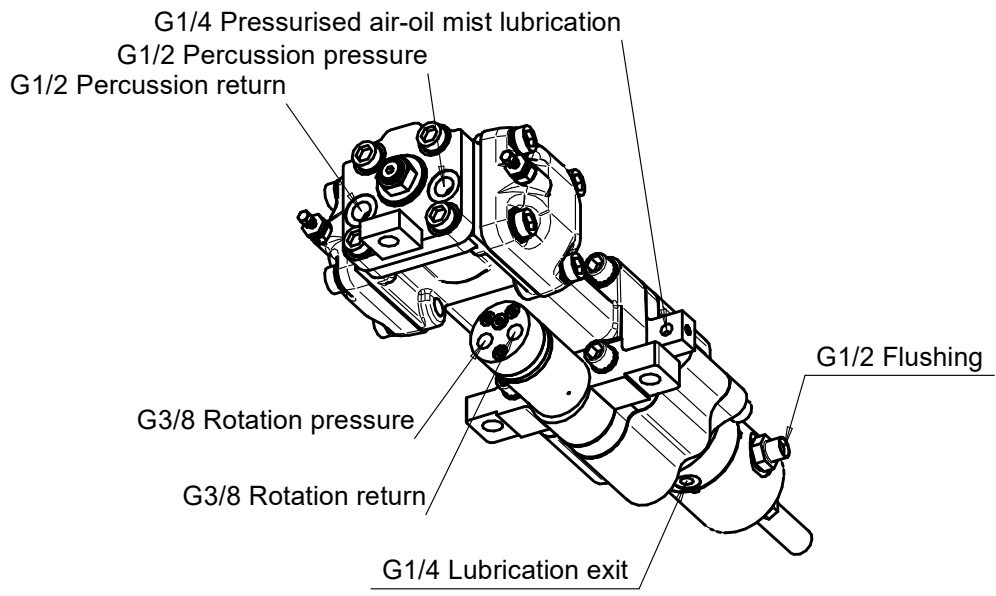
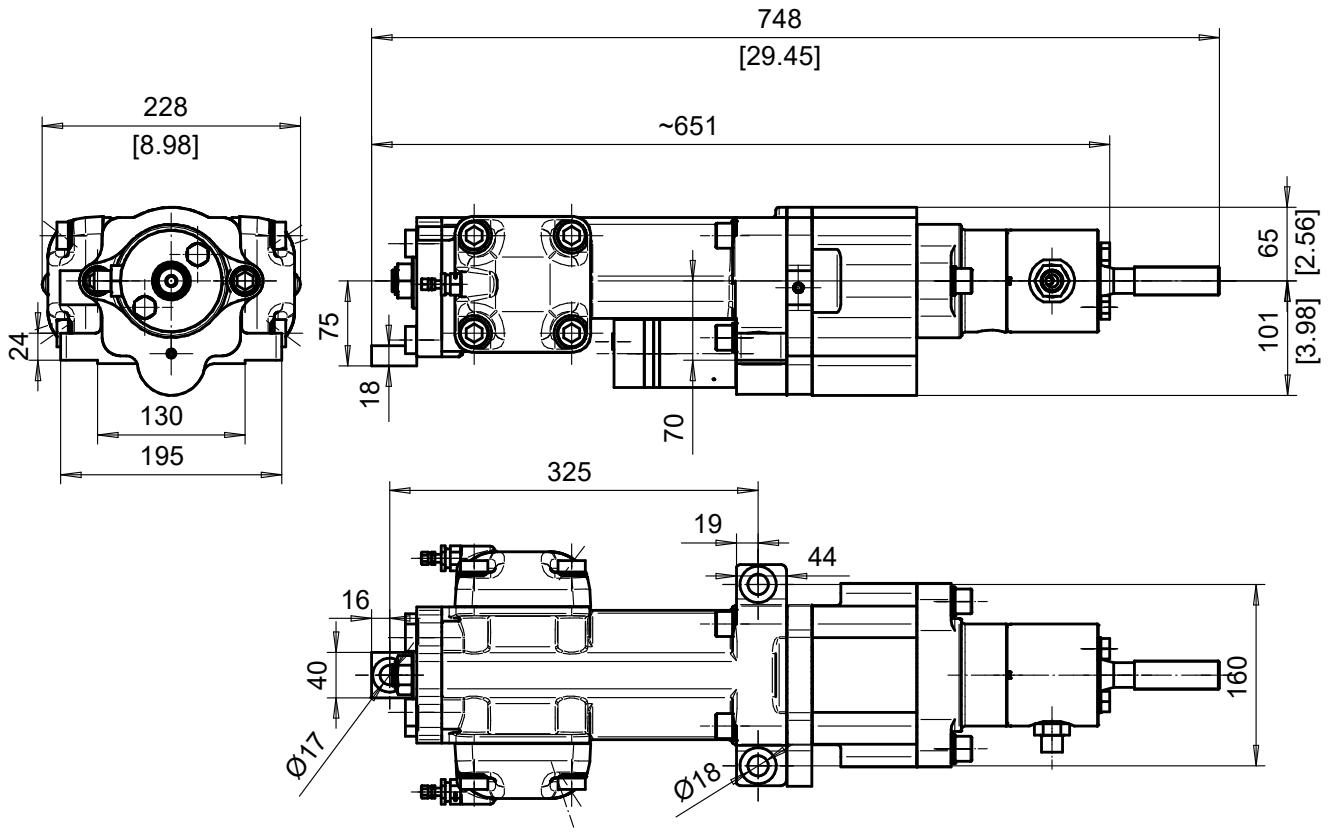

# DF530X HIGH-PERFORMANCE HYDRAULIC ROCK DRILL

Doofer DF530X is a new generation high-power, high-frequency rock drill used for general excavations and quarrying. This rock drill is equipped with a hexagonal female chuck. Flushing media can be air or water.

DF530X uses a high-energy piston shape for high-penetration speed in hard rock drilling operations and is efficient in preserving good drill tool life.

This model can be used with a Doofer original drill feed system component kit.



**CIVIL ENGINEERING, DIMENSIONAL,  
SURFACE AND UNDERGROUND**

## TECHNICAL SPECIFICATIONS

### DOOFOR DF530X DRIFTER

NOMINAL POWER CLASS		10 kW	13.4 hp
DRILL HOLE SIZE <sup>4)</sup>		45 mm	1 3/4"
PERCUSSION FLOW		45–55 l/min	11.9–14.5 gpm
PERCUSSION PRESSURE		100–130 bar	1450–1885 psi
ROTATION MOTOR MAXIMUM FLOW <sup>1)</sup>	12.5cc	25 l/min	6.6 gpm
	20cc	25 l/min	6.6 gpm
	32cc	25 l/min	6.6 gpm
	40cc	25 l/min	6.6 gpm
	50cc	25 l/min	6.6 gpm
ROTATION TORQUE <sup>1)</sup>	12.5cc	70 Nm	52 lb-ft
	20cc	107 Nm	79 lb-ft
	32cc	177 Nm	131 lb-ft
	40cc	214 Nm	158 lb-ft
	50cc	269 Nm	198 lb-ft
ROTATION PRESSURE MAXIMUM		140 bar	2031 psi
ROTATION SPEED MAXIMUM <sup>2)</sup>	12.5cc	300 rpm	
	20cc	300 rpm	
	32cc	200 rpm	
	40cc	163 rpm	
	50cc	130 rpm	
LUBRICATION	Air-oil mist	125–200 g/h	4.9–7.8 fl oz/h (1.4–2.3 dl/h)
LUBRICATION PRESSURE		4–7 bar	58–101 psi
LUBRICATION AIR FLOW		200–300 l/min	53–79 gpm
FLUSHING AIR PRESSURE <sup>3)</sup>		5–12 bar	73–174 psi
FLUSHING AIR FLOW <sup>3)</sup>		700–1200 l/min	185–317 gpm
FLUSHING WATER PRESSURE <sup>3)</sup>		5–12 bar	73–174 psi
FLUSHING WATER FLOW <sup>3)</sup>		25–40 l/min	6.6–10.6 gpm
RECOMMENDED MAXIMUM FEED FORCE		6 kN	1348 lbf
WEIGHT		55 kg	121 lb
SHANK SIZE		108mm [4 1/4"] * 22mm [7/8"] or 25mm[1"]	

<sup>1)</sup> Intermittent value.

<sup>2)</sup> Continuous value. Maximum recommended speed 300 rpm.

<sup>3)</sup> Actual values vary according to drilling conditions and equipment.

<sup>4)</sup> Maximum drill hole size in normal drilling applications.

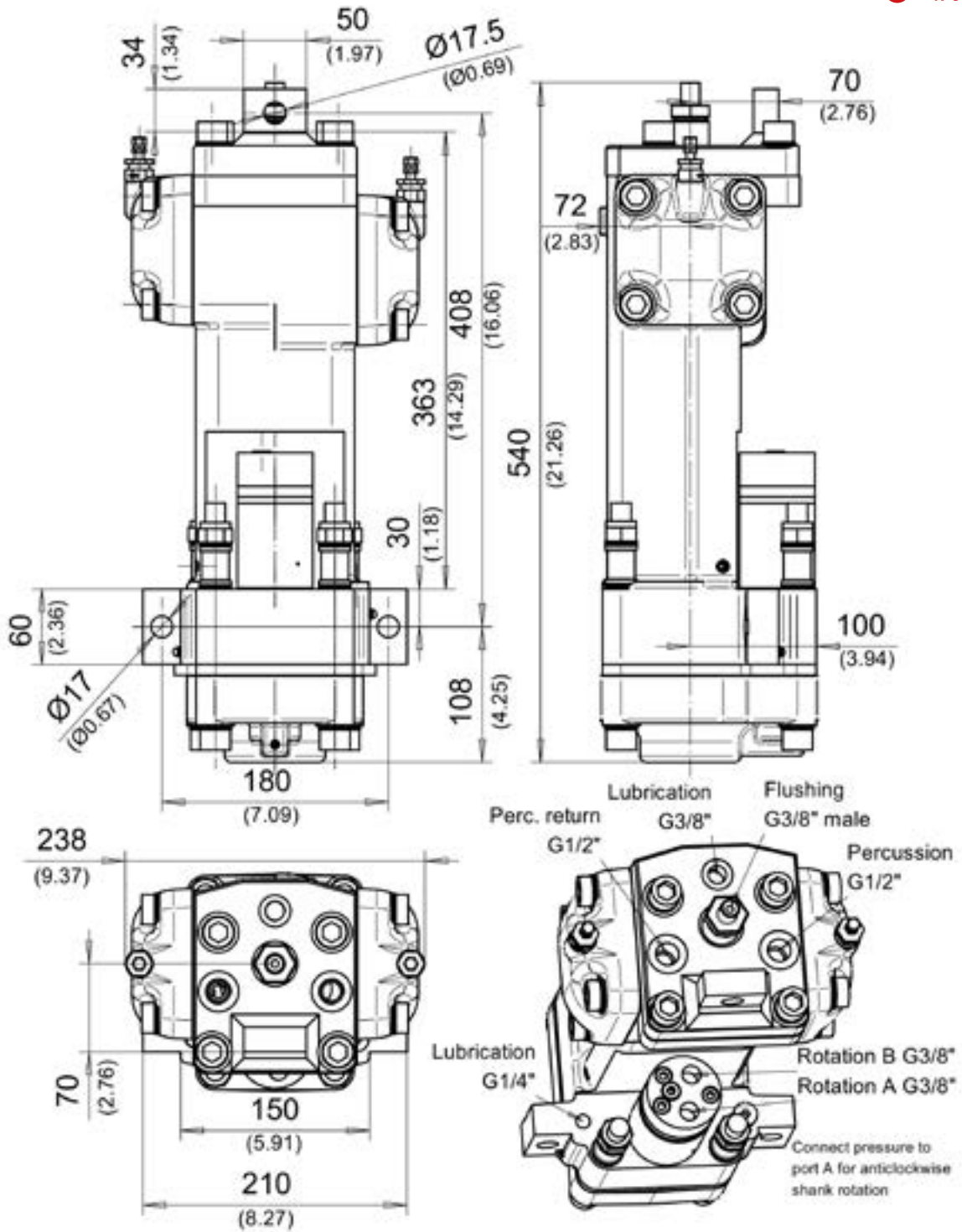

Alternative models for Doofor DF530X include Doofor DF530S with male shank adapter and Doofor DF530L with two side rotation motors for extra torque. New model DF530XS combines male or female shank adapters with short overall length.



# DOOFOR DF530L HIGH-PERFORMANCE HYDRAULIC ROCK DRILLS

The DF530L provides extra torque with two rotation motors and male shank adapters. DF530L is a high-performance rock drill offering high rotation speed capacity for general excavations, mining, and quarrying projects.

The Doofor DF530L can be used with a Doofor original drill feed system component kit.



**CIVIL ENGINEERING,  
SURFACE AND UNDERGROUND**

## TECHNICAL SPECIFICATIONS

### DOOFOR DF530L DRIFTERS

NOMINAL POWER CLASS		10 kW	13.4 hp
DRILL HOLE SIZE <sup>4)</sup>		45 mm	1 3/4"
PERCUSSION FLOW		45–55 l/min	11.9–14.5 gpm
PERCUSSION PRESSURE		100–130 bar	1450–1885 psi
LUBRICATION	Air-oil mist	125–200 g/h	4.9–7.8 fl oz/h (1.4–2.3 dl/h)
LUBRICATION PRESSURE		4–7 bar	58–101 psi
LUBRICATION AIR FLOW		200–300 l/min	53–79 gpm
FLUSHING AIR PRESSURE <sup>3)</sup>		5–12 bar	73–174 psi
FLUSHING AIR FLOW <sup>3)</sup>		700–1200 l/min	185–317 gpm
FLUSHING WATER PRESSURE <sup>3)</sup>		5–12 bar	73–174 psi
FLUSHING WATER FLOW <sup>3)</sup>		25–40 l/min	6.6–10.6 gpm
RECOMMENDED MAXIMUM FEED FORCE		6 kN	1348 lbf
SHANK SIZE		Male R28, R32 (R38, T38 in HD model)	
WEIGHT		83 kg	[183 lb]
ROTATION MOTOR MAXIMUM FLOW <sup>1)</sup>	2x 20cc	50 l/min	(13.2 gpm)
	2x 32cc	50 l/min	(13.2 gpm)
	2x 40cc	50 l/min	(13.2 gpm)
	2x 50cc	50 l/min	(13.2 gpm)
ROTATION TORQUE <sup>1)</sup>	2x 20cc	181 Nm	[131 lb-ft]
	2x 32cc	295 Nm	[218 lb-ft]
	2x 40cc	363 Nm	[268 lb-ft]
	2x 50cc	456 Nm	[336 lb-ft]
ROTATION SPEED MAXIMUM <sup>2)</sup>	2x 20cc	300 rpm	
	2x 32cc	240 rpm	
	2x 40cc	190 rpm	
	2x 50cc	154 rpm	
ROTATION PRESSURE MAXIMUM		140 bar	2031 psi

1) Intermittent value.

2) Continuous value. Maximum recommended speed 300 rpm.

3) Actual values vary according to drilling conditions and equipment.

4) Maximum drill hole size in normal drilling applications.

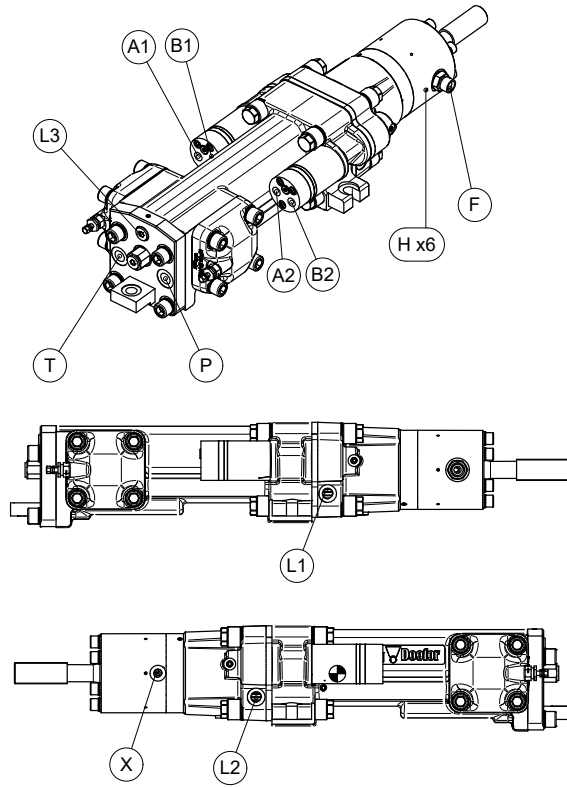

- A1 & A2) G3/8 Rotation A - connected together with a T-adaptor.
- B1 & B2) G3/8 Rotation B - connected together with a T-adaptor.
- F) G1/2 Flushing.
- H) Flushing seal leak indicator hole.
- L1) G1/4 Pressurised air-oil mist lubrication.
- L2) G1/4 Plug, alternative to L1
- L3) Plug.
- P) G1/2 Percussion pressure.
- T) G1/2 Percussion return to tank.
- X) G1/4 Lubrication exit.

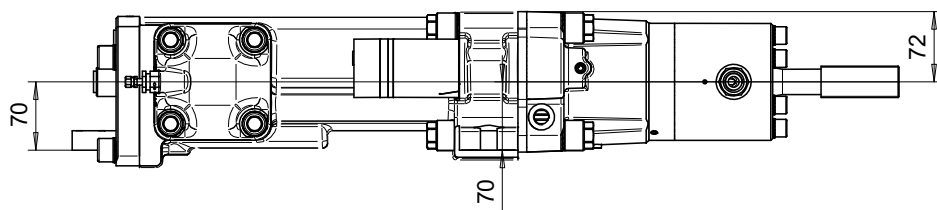
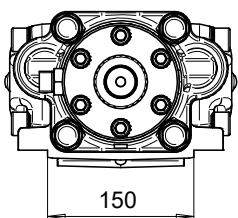
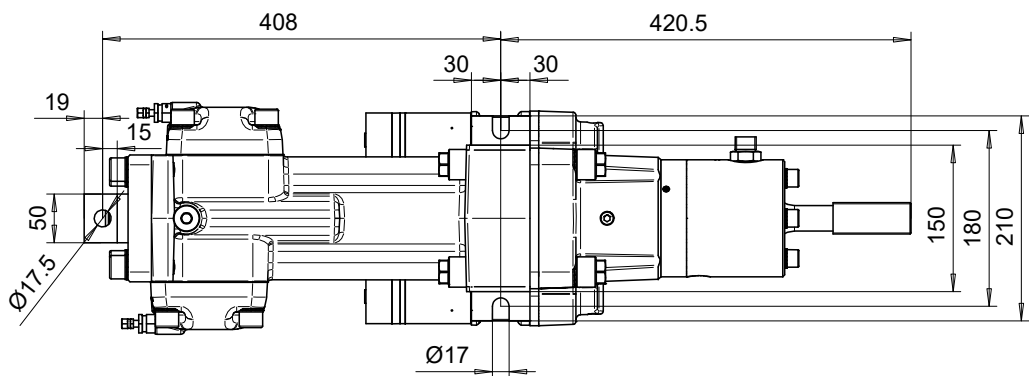

# DF530S HIGH-PERFORMANCE HYDRAULIC ROCK DRILL



**CIVIL ENGINEERING,  
SURFACE AND UNDERGROUND**

Doofor DF530S is a new generation, high-power, high-frequency rock drill used for general excavations, mining, and quarrying. This rock drill is equipped with a separated flushing box with side connection. Flushing is possible with water or air.

DF530S offers a long service life due to its simple, modular construction which makes maintenance easy and affordable.

This model can be used with a Doofor original drill feed system component kit.

## TECHNICAL SPECIFICATIONS

### DOOFOR DF530S DRIFTER

<b>NOMINAL POWER CLASS</b>		10 kW	13.4 hp
<b>DRILL HOLE SIZE <sup>4)</sup></b>		45 mm	1 3/4"
<b>PERCUSSION FLOW</b>		45–55 l/min	11.9–14.5 gpm
<b>PERCUSSION PRESSURE</b>		100–130 bar	1450–1885 psi
<b>ROTATION MOTOR MAXIMUM FLOW <sup>1)</sup></b>	12.5cc	25 l/min	6.6 gpm
	20cc	25 l/min	6.6 gpm
	32cc	25 l/min	6.6 gpm
	40cc	25 l/min	6.6 gpm
	50cc	25 l/min	6.6 gpm
<b>ROTATION TORQUE <sup>1)</sup></b>	12.5cc	70 Nm	52 lb-ft
	20cc	107 Nm	79 lb-ft
	32cc	177 Nm	131 lb-ft
	40cc	214 Nm	158 lb-ft
	50cc	269 Nm	198 lb-ft
<b>ROTATION PRESSURE MAXIMUM</b>		140 bar	2031 psi
<b>ROTATION SPEED MAXIMUM <sup>2)</sup></b>	12.5cc	300 rpm	
	20cc	300 rpm	
	32cc	200 rpm	
	40cc	163 rpm	
	50cc	130 rpm	
<b>LUBRICATION</b>	Air-oil mist	125–200 g/h	4.9–78 fl oz/h (1.4–2.3 dl/h)
<b>LUBRICATION PRESSURE</b>		4–7 bar	58–101 psi
<b>LUBRICATION AIR FLOW</b>		200–300 l/min	53–79 gpm
<b>FLUSHING AIR PRESSURE <sup>3)</sup></b>		5–12 bar	73–174 psi
<b>FLUSHING AIR FLOW <sup>3)</sup></b>		700–1200 l/min	185–317 gpm
<b>FLUSHING WATER PRESSURE <sup>3)</sup></b>		5–12 bar	73–174 psi
<b>FLUSHING WATER FLOW <sup>3)</sup></b>		25–40 l/min	6.6–10.6 gpm
<b>RECOMMENDED MAXIMUM FEED FORCE</b>		6 kN	1348 lbf
<b>WEIGHT</b>		77 kg	170 lb
<b>SHANK SIZE</b>		Male R28, R32	

<sup>1)</sup> Intermittent value.

<sup>2)</sup> Continuous value. Maximum recommended speed 300 rpm.

<sup>3)</sup> Actual values vary according to drilling conditions and equipment.

<sup>4)</sup> Maximum drill hole size in normal drilling applications.

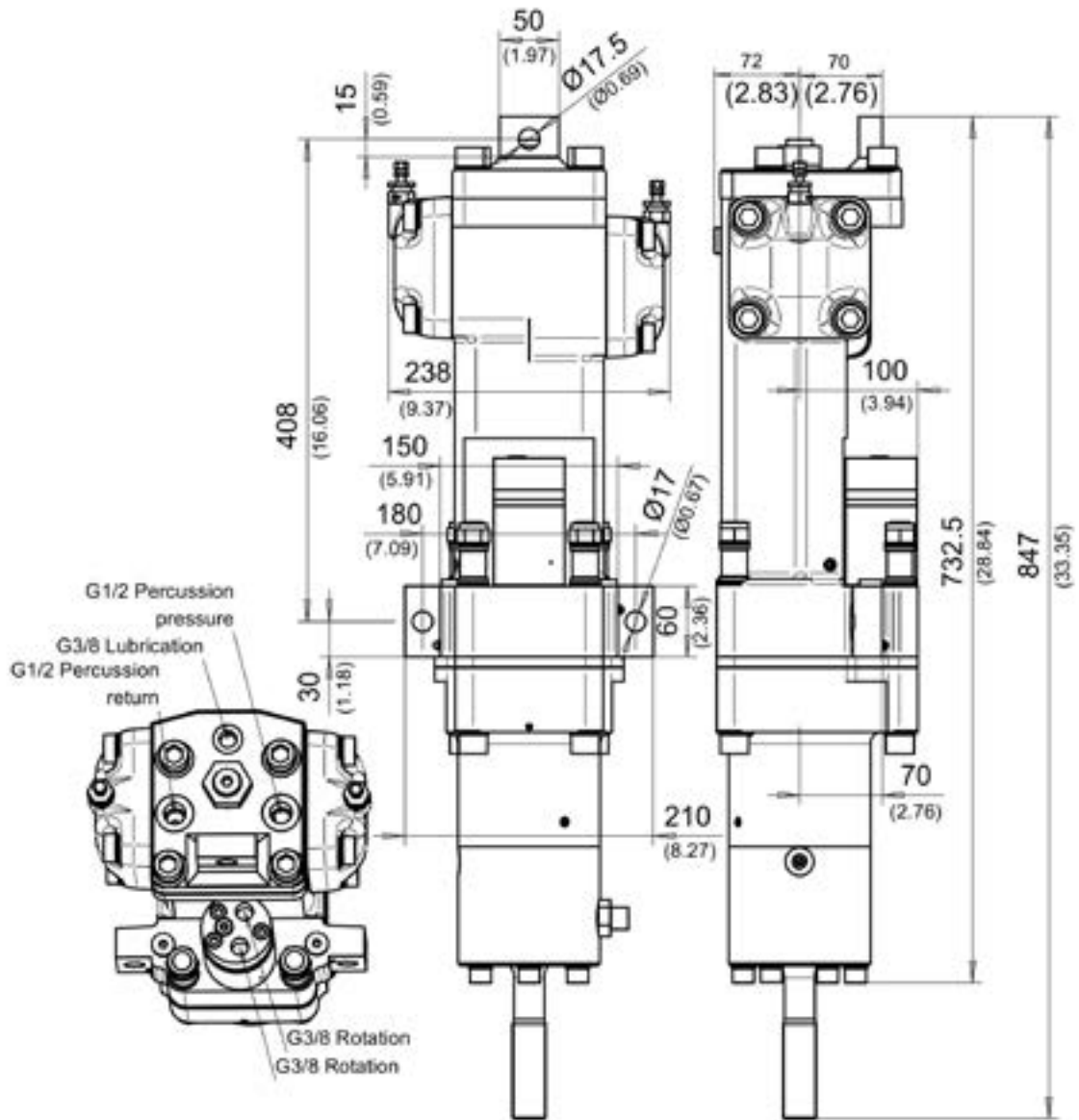

Alternative models for Doofor DF530S include Doofor DF530X with hexagonal chuck and Doofor DF530L with two side rotation motors for extra torque.



# DF530XS HIGH-PERFORMANCE HYDRAULIC ROCK DRILL

Doofor DF530XS is a new generation high-power, high-frequency rock drill used for bolting, general excavations and quarrying. This rock drill combines female or male shank adapters with extra short desing. Flushing media can be air or water. The rock drill is exceptionally compact, allowing operation in confined spaces.

DF530XS uses a high-energy piston shape for high-penetration speed in hard rock drilling operations and is efficient in preserving good drill tool life.

This model can be used with a Doofor original drill feed system component kit.



**CIVIL ENGINEERING AND UNDERGROUND**

## TECHNICAL SPECIFICATIONS

### DOOFOR DF530XS DRIFTER

NOMINAL POWER CLASS		10 kW	13.4 hp
DRILL HOLE SIZE <sup>4)</sup>		45 mm	1 3/4"
PERCUSSION FLOW		45–55 l/min	11.9–14.5 gpm
PERCUSSION PRESSURE		100–130 bar	1450–1885 psi
ROTATION MOTOR MAXIMUM FLOW <sup>1)</sup>	12.5cc	25 l/min	6.6 gpm
	20cc	25 l/min	6.6 gpm
	32cc	25 l/min	6.6 gpm
	40cc	25 l/min	6.6 gpm
	50cc	25 l/min	6.6 gpm
ROTATION TORQUE <sup>1)</sup>	12.5cc	70 Nm	52 lb-ft
	20cc	107 Nm	79 lb-ft
	32cc	177 Nm	131 lb-ft
	40cc	214 Nm	158 lb-ft
	50cc	269 Nm	198 lb-ft
ROTATION PRESSURE MAXIMUM		140 bar	2031 psi
ROTATION SPEED MAXIMUM <sup>2)</sup>	12.5cc	300 rpm	
	20cc	300 rpm	
	32cc	200 rpm	
	40cc	163 rpm	
	50cc	130 rpm	
LUBRICATION	Air-oil mist	125–200 g/h	4.9–7.8 fl oz/h (1.4–2.3 dl/h)
LUBRICATION PRESSURE		4–7 bar	58–101 psi
LUBRICATION AIR FLOW		200–300 l/min	53–79 gpm
FLUSHING AIR PRESSURE <sup>3)</sup>		5–12 bar	73–174 psi
FLUSHING AIR FLOW <sup>3)</sup>		700–1200 l/min	185–317 gpm
FLUSHING WATER PRESSURE <sup>3)</sup>		5–12 bar	73–174 psi
FLUSHING WATER FLOW <sup>3)</sup>		25–40 l/min	6.6–10.6 gpm
RECOMMENDED MAXIMUM FEED FORCE		6 kN	1348 lbf
WEIGHT		70 kg	154 lb

#### SHANK SIZE

<sup>1)</sup> Intermittent value.

<sup>2)</sup> Continuous value. Maximum recommended speed 300 rpm.

<sup>3)</sup> Actual values vary according to drilling conditions and equipment.

<sup>4)</sup> Maximum drill hole size in normal drilling applications.

Female R32, other sizes such as R28 or male R28, R32 possible.

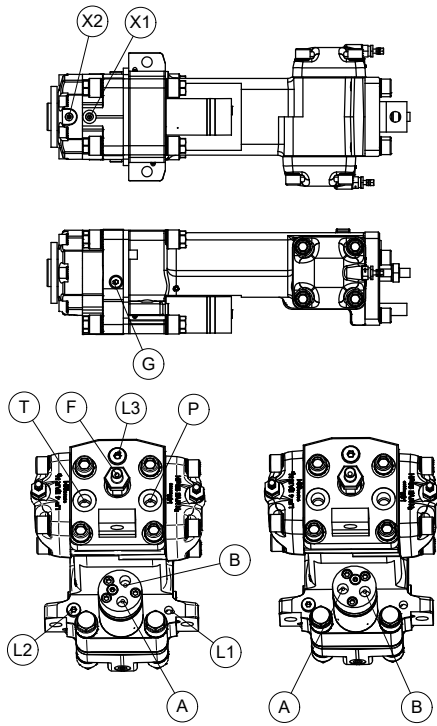

- A) G3/8 Rotation A
- B) G3/8 Rotation B
- F) G3/8 Flushing
- L1) G1/4 Pressurised air-oil mist lubrication.
- L2) G1/4 Plug,
- L3) Plug.
- P1) G1/2 Percussion pressure.
- T) G3/4 percussion return to tank.
- X1 and X2) Lubrication exit.

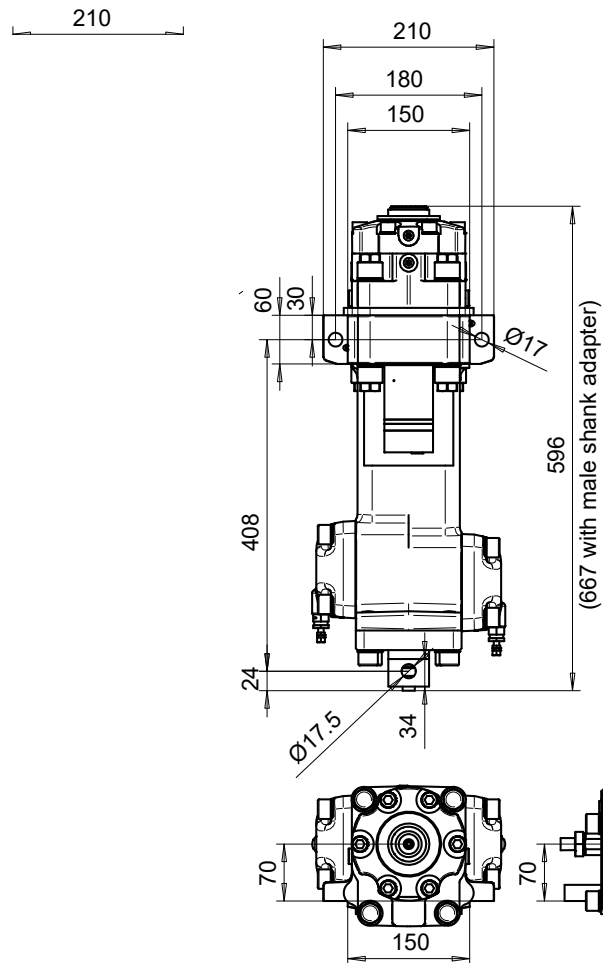

Alternative models for Doofor DF530XS include Doofor DF530X with female hexagonal chuck, DF530S with male shank adapter and Doofor DF530L with two side rotation motors for extra torque.

# DF538L HIGH-PERFORMANCE HYDRAULIC ROCK DRILL

Doofor DF538L is a highly efficient hydraulic rock drill equipped with two rotation motors capable of generating high levels of torque. This rock drill features a robust gearbox which maximizes durability for surface and underground use. DF538L application varies from general excavations, tunneling or mining. This model can be used with a Doofor original drill feed system component kit.



**CIVIL ENGINEERING,  
SURFACE AND UNDERGROUND**

## TECHNICAL SPECIFICATIONS

### DOOFOR DF538L DRIFTER

NOMINAL POWER CLASS		13 kW	17.4 hp
DRILL HOLE SIZE <sup>4)</sup>		57 mm	2 1/4"
PERCUSSION FLOW		65–85 l/min	17–23 gpm
PERCUSSION PRESSURE		110–140 bar	1600–2050 psi
ROTATION MOTOR MAXIMUM FLOW <sup>1)</sup>	2x 20cc	50 l/min	13.2 gpm
	2x 32cc	50 l/min	13.2 gpm
	2x 40cc	50 l/min	13.2 gpm
	2x 50cc	50 l/min	13.2 gpm
ROTATION TORQUE <sup>1)</sup>	2x 20cc	181 Nm	131 lb-ft
	2x 30cc	295 Nm	218 lb-ft
	2x 40cc	363 Nm	268 lb-ft
	2x 50cc	456 Nm	336 lb-ft
ROTATION PRESSURE MAXIMUM		140 bar	2031 psi
ROTATION SPEED MAXIMUM <sup>2)</sup>	2x 20cc	300 rpm	
	2x 32cc	240 rpm	
	2x 40cc	190 rpm	
	2x 50cc	154 rpm	
LUBRICATION	Air-oil mist	150–250 g/h	5.9–9.8 fl oz/h (1.7–2.9 dl/h)
LUBRICATION PRESSURE		4–7 bar	58–101 psi
LUBRICATION AIR FLOW		200–300 l/min	53–79 gpm
FLUSHING AIR PRESSURE <sup>3)</sup>		5–10 bar	73–145 psi
FLUSHING AIR FLOW <sup>3)</sup>		1500–2500 l/min	396–660 gpm
FLUSHING WATER PRESSURE <sup>3)</sup>		4–12 bar	58–174 psi
FLUSHING WATER FLOW <sup>3)</sup>		30–40 l/min	8–11 gpm
RECOMMENDED MAXIMUM FEED FORCE		10 kN	2250 lbf
WEIGHT		83 kg	183 lb
SHANK SIZE		R32, R38, T38	

<sup>1)</sup> Intermittent value.

<sup>2)</sup> Continuous value. Maximum recommended speed 300 rpm.

<sup>3)</sup> Actual values vary according to drilling conditions and equipment.

<sup>4)</sup> Maximum drill hole size in normal drilling applications.

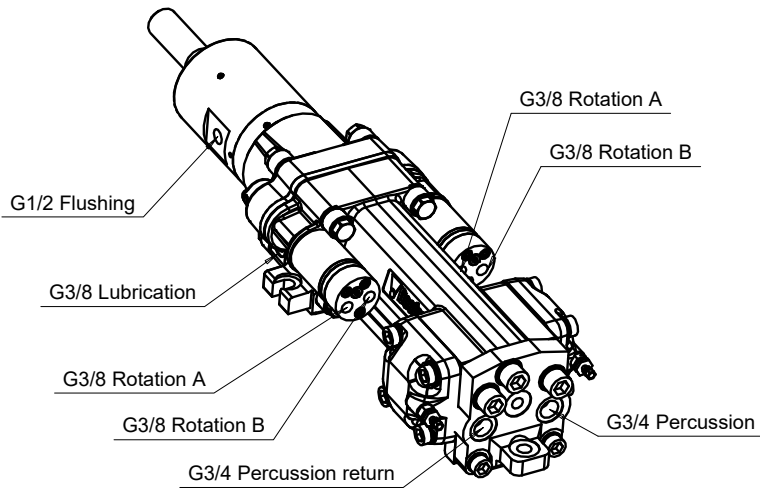
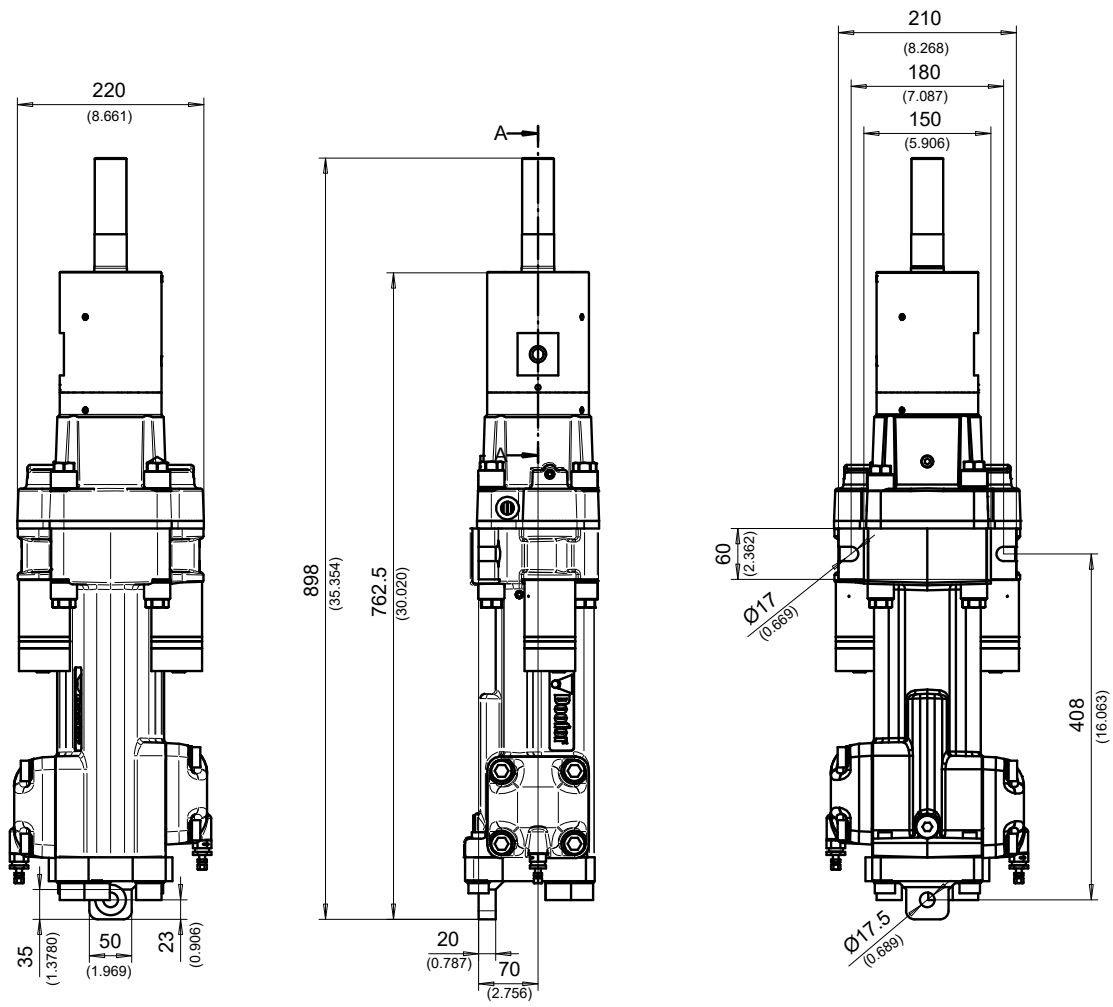

# DF540L-BLT HIGH-PERFORMANCE HYDRAULIC ROCK DRILL



**UNDERGROUND**

Doofer DF540L-BLT is a hydraulic rock drill designed for bolting, general excavations, and underground production drilling. It has a very low overhead, only 82.5mm from the center line. The rotation motor of the Doofer DF540L-BLT can be installed on the right-hand or the left-hand side. Flushing media can be water or air. Optimized internal oil flow construction effectively preserves hydraulic power.

## TECHNICAL SPECIFICATIONS

### DOOFOR DF540L-BLT DRIFTER

NOMINAL POWER CLASS		14 kW	18.8 hp
DRILL HOLE SIZE <sup>5)</sup>		64 mm	2 1/2"
PERCUSSION FLOW		90 l/min	23.8 gpm
PERCUSSION PRESSURE		140 bar	2030 psi
ROTATION MOTOR MAXIMUM FLOW <sup>1)4)</sup>	80cc	80 l/min	21.1 gpm
	125cc	90 l/min	23.8 gpm
	160cc	90 l/min	23.8 gpm
ROTATION TORQUE <sup>1)</sup>	80cc	504 Nm	372 lb-ft
	125cc	796 Nm	587 lb-ft
	160cc	975 Nm	719 lb-ft
ROTATION PRESSURE MAXIMUM		175 bar	2540 psi
ROTATION SPEED MAXIMUM <sup>2)</sup>	80cc	250 rpm	
	125cc	250 rpm	
	160cc	250 rpm	
LUBRICATION	Air-oil mist	200-300 g/h	7.8-11.7 fl oz/h (2.3-3.5 dl/h)
LUBRICATION PRESSURE		4-7 bar	58-101 psi
LUBRICATION AIR FLOW		200-300 l/min	53-79 gpm
FLUSHING AIR PRESSURE <sup>3)</sup>		5-7 bar	73-101 psi
FLUSHING AIR FLOW <sup>3)</sup>		4000 l/min	1057 gpm
FLUSHING WATER FLOW <sup>3)</sup>		150 l/min	39.6 gpm
RECOMMENDED MAXIMUM FEED FORCE		15 kN	3372 lbf
WEIGHT		144 kg	317 lb
SHANK SIZE		Male R32, R38, T38 and female R32.	

<sup>1)</sup> Intermittent value.

<sup>2)</sup> Continuous value. Maximum recommended speed 250 rpm.

<sup>3)</sup> Actual values vary according to drilling conditions and equipment.

<sup>4)</sup> Value for default OMS motors only.

<sup>5)</sup> Maximum drill hole size in normal drilling applications.



- A) G1/2 Rotation A
- B) G1/2 Rotation B
- X) G3/8 Lubrication exit
- F) G1/2 Flushing
- H) Flushing seal leak indicator hole, 4 pcs
- L) G1/4 Pressurised air-oil mist lubrication
- P1) G3/4 Percussion pressure
- P2) G3/4 Plug, alternative to P1, 2 pcs
- T1) G3/4 Percussion return to tank
- T2) G3/4 Plug, alternative to T1, 2 pcs

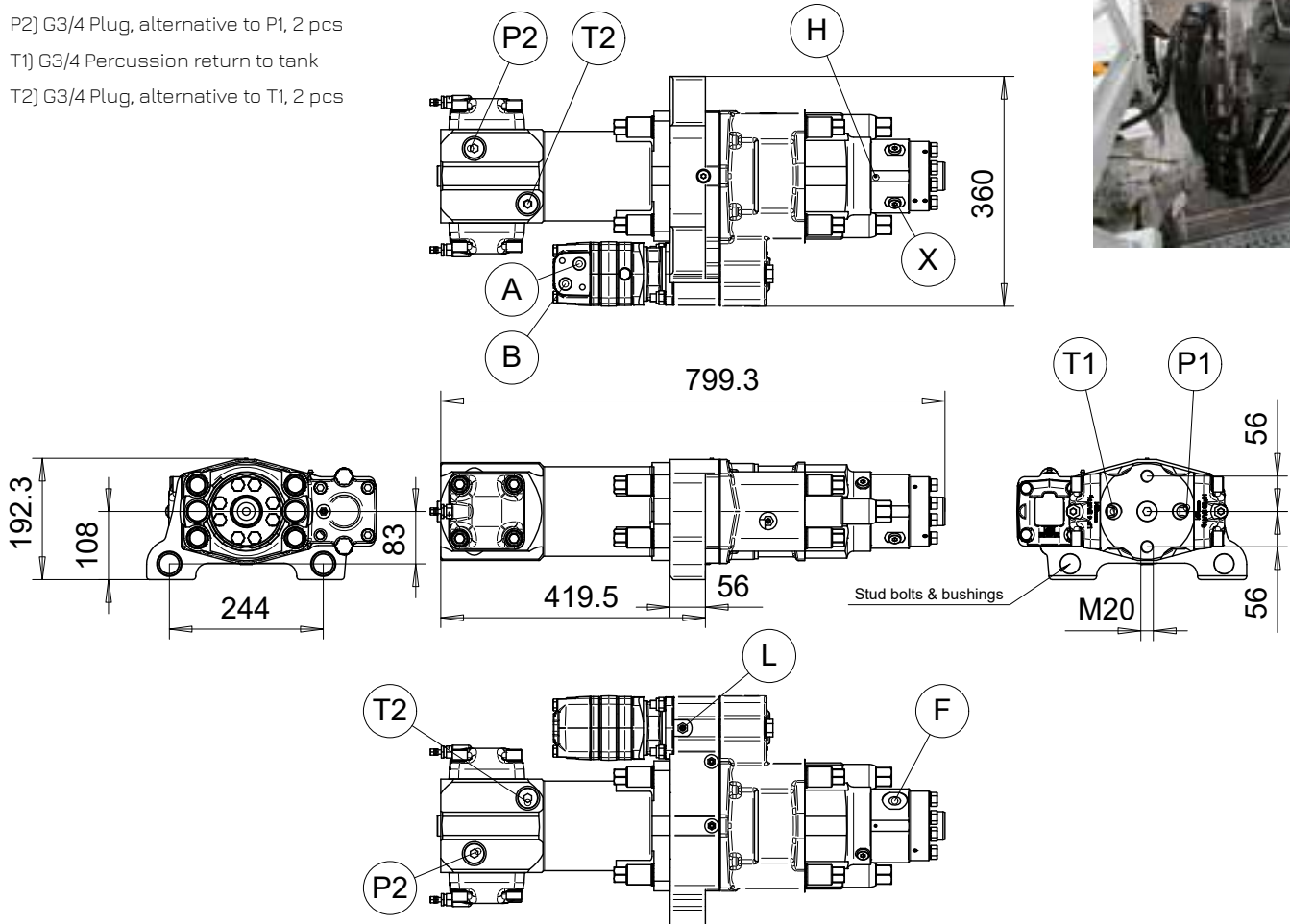

Motor can be on the left or on the right side. Motor ports can be turned. Back port versions of motor are available.

Flushing head can be turned 180 degrees. Accumulators can be turned to any of the four positions (depending on motor.)

Doofor DF540L-BLT can be equipped with BLTG-, BLTF- and 2M options and a standard Doofor flushing system, similar to DF550L or DF560L.



**EMBEDDED BUSHINGS**

**STUD BOLT AND HAT NUT**

# DF550L HIGH-PERFORMANCE HYDRAULIC ROCK DRILL



Doofor DF550L maintains its durable, universal structure similar to its predecessors. This rock drill was designed with power and multipurpose in mind. The rotation motor can be installed on the right or left-hand side and further customization is possible with BLT attachment option for bolting application.

The DF550L has a separated flushing box and flushing media can be water or air. The standard DF550L model can be used to enhance your drilling operations in projects including underground production drilling, tunnelling, and bolting. This rock drill has a very low profile, only 84mm from the drill center line.

**SURFACE AND UNDERGROUND**

## TECHNICAL SPECIFICATIONS

### DOOFOR DF550L DRIFTER

<b>NOMINAL PERCUSSION POWER</b>		17 kW	22.8 hp
<b>DRILL HOLE SIZE <sup>5)</sup></b>		76 mm	3"
<b>PERCUSSION FLOW</b>		90–120 l/min	23.8–31.7 gpm
<b>PERCUSSION PRESSURE</b>		80–160 bar	1160–2321 psi
<b>ROTATION MOTOR MAXIMUM FLOW <sup>1) 4)</sup></b>	80cc	80 l/min	21.1 gpm
	100cc	90 l/min	23.8 gpm
	125cc	90 l/min	23.8 gpm
	160cc	90 l/min	23.8 gpm
	200cc	90 l/min	23.8 gpm
<b>ROTATION TORQUE <sup>1)</sup></b>	80cc	504 Nm	372 lb-ft
	100cc	634 Nm	468 lb-ft
	125cc	796 Nm	587 lb-ft
	160cc	975 Nm	719 lb-ft
	200cc	1170 Nm	863 lb-ft
<b>ROTATION PRESSURE <sup>4)</sup> (MAXIMUM)</b>		175 bar (275 bar)	2540 psi (3989 psi)
<b>ROTATION SPEED MAXIMUM <sup>2)</sup></b>	80cc	250 rpm	
	100cc	250 rpm	
	125cc	250 rpm	
	160cc	250 rpm	
	200cc	225 rpm	
<b>LUBRICATION</b>	Air-oil mist	200–300 g/h	7.8–11.7 fl oz/h (2.3–3.5 dl/h)
<b>LUBRICATION PRESSURE</b>		6–7 bar	87–101 psi
<b>LUBRICATION AIR FLOW</b>		200–300 l/min	53–79 gpm
<b>FLUSHING AIR PRESSURE <sup>3)</sup></b>		5–7 bar	73–101 psi
<b>FLUSHING AIR FLOW <sup>3)</sup></b>		4000 l/min	1057 gpm
<b>FLUSHING WATER FLOW <sup>3)</sup></b>		50–150 l/min	13–40 gpm
<b>RECOMMENDED MAXIMUM FEED FORCE</b>		15 kN	3372 lbf
<b>WEIGHT</b>		151 kg	333 lb
<b>SHANK SIZE</b>		R32, R38, T38 (T45 with special options)	

<sup>1)</sup> Intermittent value.

<sup>2)</sup> Continuous value. Maximum recommended speed 250 rpm.

<sup>3)</sup> Actual values vary according to drilling conditions and equipment.

<sup>4)</sup> Value for default OMS motors only.

<sup>5)</sup> Maximum drill hole size in normal drilling applications.

## DIMENSIONS

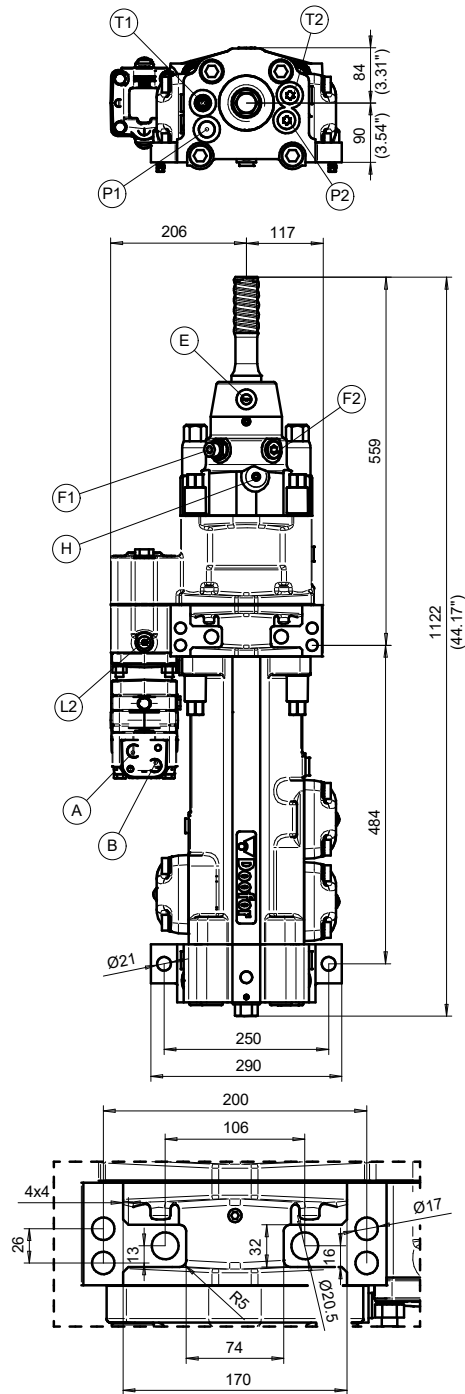
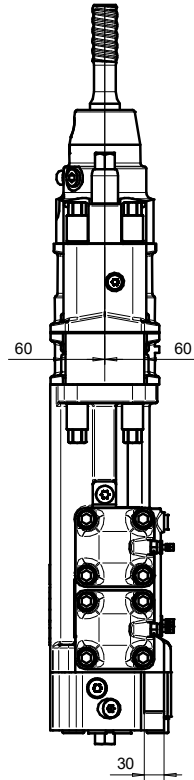
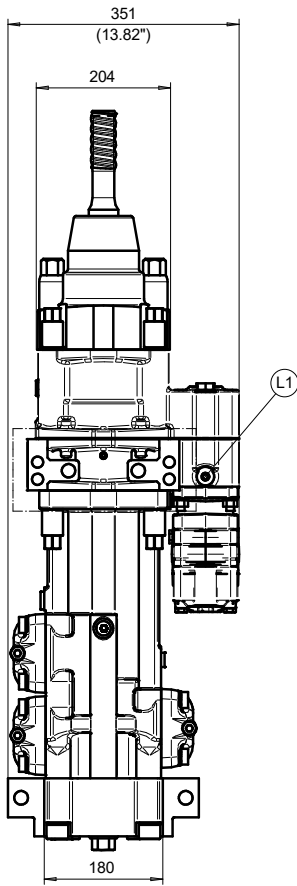

- A) G1/2 Rotation A
- B) G1/2 Rotation B
- E) G3/8 Lubrication exit
- F1) G1/2 Flushing (Optional: G3/4, JIC7/8, JIC 1 1/16)
- F2) G1/2 Alternative to F1 (same options)
- H) Flushing seal leak indicator hole
- L1) G1/4 Pressurised air-oil mist lubrication
- L2) G1/4 Plug, alternative to L1
- P1) G3/4 Percussion pressure
- P2) G3/4 Plug, alternative to P1
- T1) G3/4 percussion return to tank
- T2) G3/4 Plug, alternative to L1

Motor can be on the left or on the right side. Motor ports can be turned. Back port versions of motor are available. Flushing head can be turned 180 degrees. Accumulators can be turned to any of the four positions (depending on motor.) Doofor DF550L can be equipped with BLT-, BLTG-, BLTF- and 2M options. Special heatproof version for blast furnace tap hole drilling available.



# DF560L HIGH-PERFORMANCE HYDRAULIC ROCK DRILL



**SURFACE AND UNDERGROUND**

Doofor DF560L is a next generation hydraulic rock drill designed to ensure high-drilling capacity and optimal drill steel lifetime. Patented percussion channeling minimizes the number of parts requiring maintenance, making this rock drill one of the best on the market in terms of power to weight ratio. Original modular design makes this rock drill also one of the easiest to service. The rotation motor can be installed on the right or left-hand side. Flushing media can be air or water. Customization options include BLT and BLTF variants for bolting and grouting.

DF560L can be used in underground production drilling and tunnelling applications. This rock drill has a very low profile, only 84mm from the drill center line.

## TECHNICAL SPECIFICATIONS

### DOOFOR DF560L DRIFTER

<b>NOMINAL PERCUSSION POWER</b>		20 kW	26.8 hp
<b>DRILL HOLE SIZE <sup>5)</sup></b>		89 mm	3 1/2"
<b>PERCUSSION FLOW</b>		110–130 l/min	29.1–34.3 gpm
<b>PERCUSSION PRESSURE</b>		80–150 bar	1160–2176 psi
<b>ROTATION MOTOR MAXIMUM FLOW <sup>1) 4)</sup></b>	80cc	80 l/min	21.1 gpm
	100cc	90 l/min	23.8 gpm
	125cc	90 l/min	23.8 gpm
	160cc	90 l/min	23.8 gpm
	200cc	90 l/min	23.8 gpm
<b>ROTATION TORQUE <sup>1)</sup></b>	80cc	504 Nm	372 lb-ft
	100cc	634 Nm	468 lb-ft
	125cc	796 Nm	587 lb-ft
	160cc	975 Nm	719 lb-ft
	200cc	1170 Nm	863 lb-ft
<b>ROTATION PRESSURE <sup>4)</sup> (MAXIMUM)</b>		175 bar (275 bar)	2540 psi (3989 psi)
<b>ROTATION SPEED MAXIMUM <sup>2)</sup></b>	80cc	250 rpm	
	100cc	250 rpm	
	125cc	250 rpm	
	160cc	250 rpm	
	200cc	225 rpm	
<b>LUBRICATION</b>	Air-oil mist	200–300 g/h	7.8–11.7 fl. oz/h (2.3–3.5 dl/h)
<b>LUBRICATION PRESSURE</b>		6–7 bar	87–101 psi
<b>LUBRICATION AIR FLOW</b>		200–300 l/min	53–79 gpm
<b>FLUSHING AIR PRESSURE <sup>3)</sup></b>		5–7 bar	73–101 psi
<b>FLUSHING AIR FLOW <sup>3)</sup></b>		4000 l/min	1057 gpm
<b>FLUSHING WATER FLOW <sup>3)</sup></b>		50–150 l/min	13–40 gpm
<b>RECOMMENDED MAXIMUM FEED FORCE</b>		15 kN	3372 lbf
<b>WEIGHT</b>		151 kg	333 lb
<b>SHANK SIZE</b>		R32, R38, T38, T45	

<sup>1)</sup> Intermittent value.

<sup>2)</sup> Continuous value. Maximum recommended speed 250 rpm.

<sup>3)</sup> Actual values vary according to drilling conditions and equipment.

<sup>4)</sup> Value for default DMS motors only.

<sup>5)</sup> Maximum drill hole size in normal drilling applications.

## DIMENSIONS

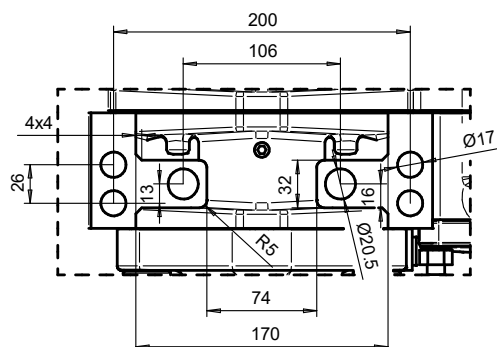
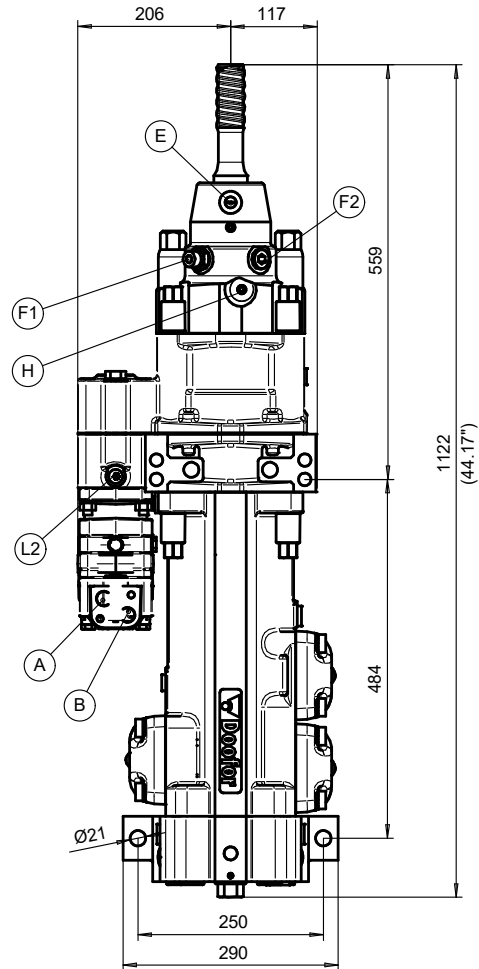
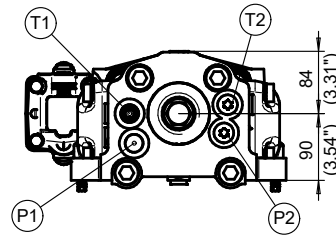
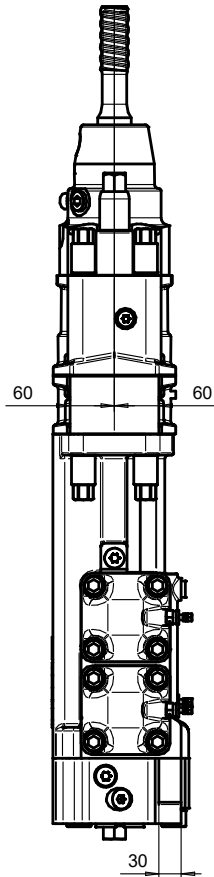
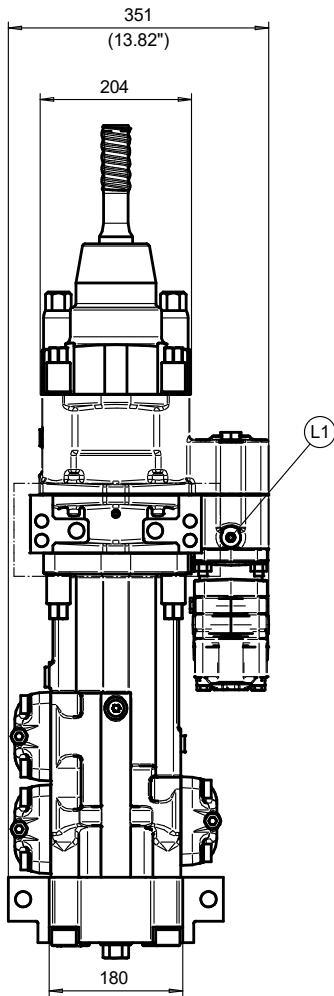

- A) G1/2 Rotation A
- B) G1/2 Rotation B
- E) G3/8 Lubrication exit
- F1) G1/2 Flushing (Optional: G3/4, JIC7/8, JIC 1 1/16)
- F2) G1/2 Alternative to F1 (same options)
- H) Flushing seal leak indicator hole
- L1) G1/4 Pressurised air-oil mist lubrication
- L2) G1/4 Plug, alternative to L1
- P1) G3/4 Percussion pressure
- P2) G3/4 Plug, alternative to P1
- T1) G3/4 percussion return to tank
- T2) G3/4 Plug, alternative to L1

Motor can be on the left or on the right side. Motor ports can be turned. Back port versions of motor are available. Flushing head can be turned 180 degrees. Accumulators can be turned to any of the four positions (depending on motor) Doofor DF560L can be equipped with BLT-, BLTG-, BLTF- and 2M options.



# OPTIONS FOR DOOFOR DF560L DF550L AND DF540L HYDRAULIC ROCK DRILLS

Besides different shank adapters and rotation motor sizes, variety of options are available for Doofor DF540L, DF550L and DF560L hydraulic rock drills.

Options improve the performance and make the product more suitable for your application.

2M option effectively doubles the torque of the rock drill.

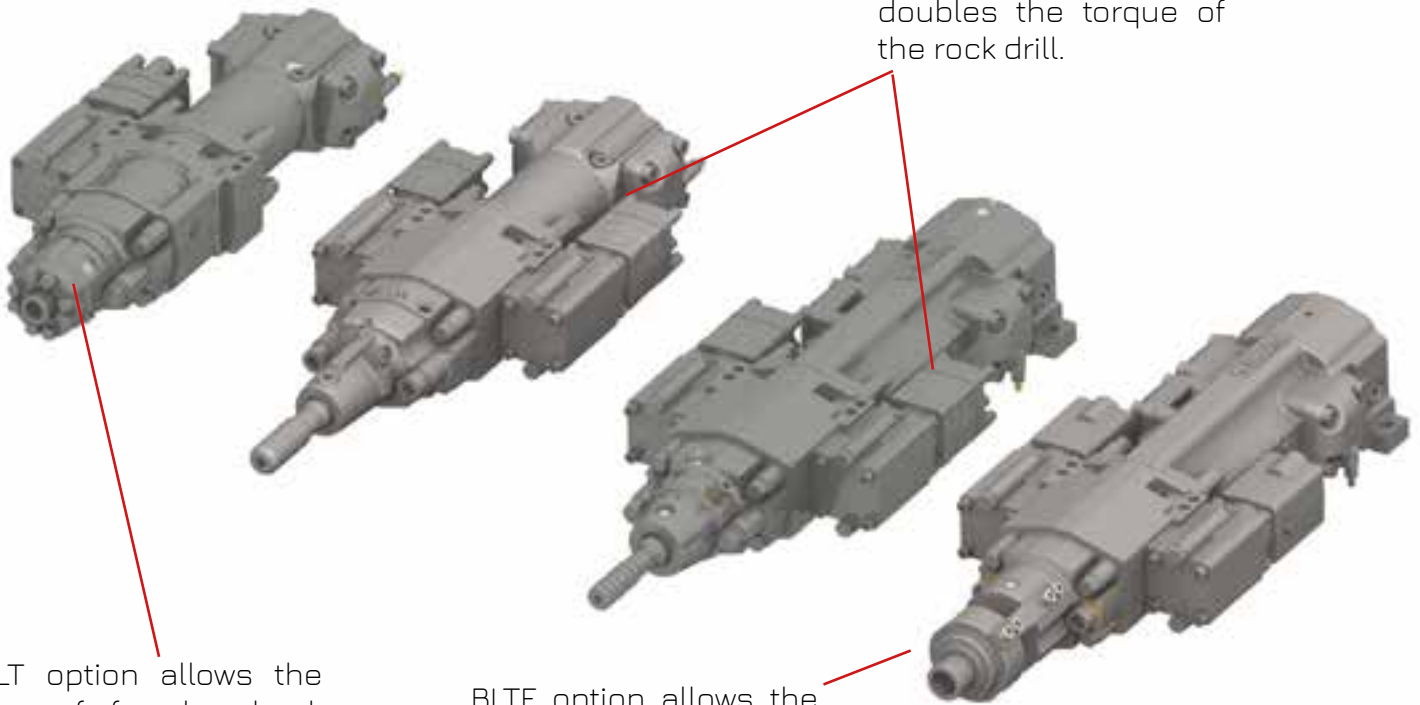

BLT option allows the use of female shank adapters up to R32. Extra seals enhance durability.

BLTG option adds even more seals, improved shank support and uses male shank adapters.

BLTF option allows the use of female shank adapters up to T38/R38 size.

Flushing head is completely separated, making it easy to use grouting fluids.



# 2M OPTION FOR HIGH TORQUE WITH TWO ROTATION MOTORS



2M option replaces the gear box with two rotation motor version. It can be attached to the Doofor DF540L, DF550L and DF560L rock drills. The option improves the performance of the rock drill by increasing rotation torque.

2M-option can be combined with BLT- and EXT-options.

## TECHNICAL SPECIFICATIONS

### 2M OPTION FOR DOOFOR DF540L, DF550L AND DF560L

ROTATION MOTOR MAXIMUM FLOW <sup>1) 4)</sup>	2x 80cc	160 l/min	42.2 gpm
	2x 125cc	180 l/min	47.6 gpm
	2x 160cc	180 l/min	47.6 gpm
ROTATION TORQUE <sup>1)</sup>	2x 80cc	1008 Nm	744 lb-ft
	2x 125cc	1592 Nm	1174 lb-ft
	2x 160cc	1950 Nm	1438 lb-ft
ROTATION PRESSURE MAXIMUM		175 bar	2540 psi
ROTATION MOTOR MAXIMUM SPEED <sup>2)</sup>	2x 80cc	250 rpm	
	2x 125cc	250 rpm	
	2x 160cc	250 rpm	

1) Intermittent value.

2) Continuous value. Maximum recommended speed 250 rpm.

3) Actual values vary according to drilling conditions and equipment.

4) Value for default DMS motors only.

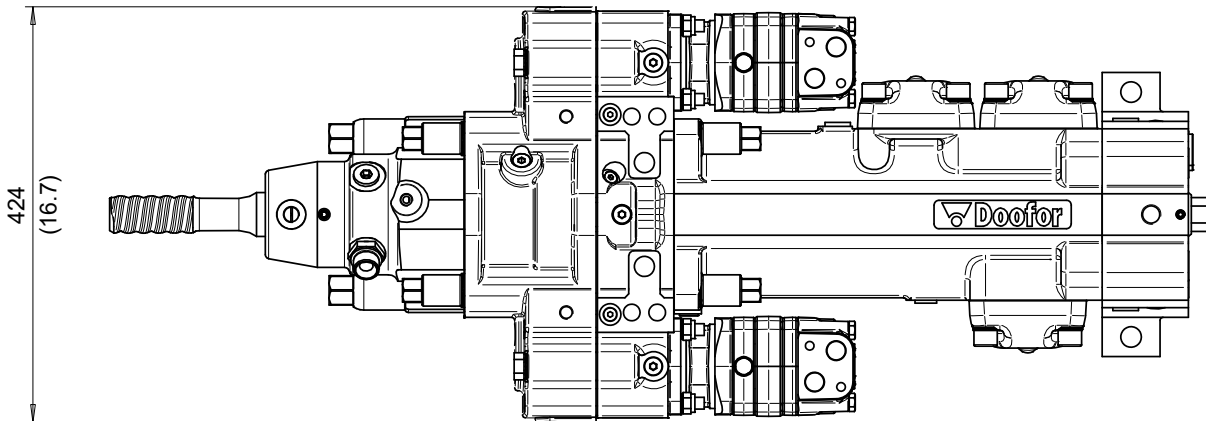



# BLT OPTION FOR BOLTING

BLT option modifies the flushing head of the rock drill. It has a short flushing head for bolting and general drilling. It can also be used for tunnelling and general excavations.

BLT option can be used with Doofor DF540L, DF550L and DF560L rock drills. It can also be used together with 2M option.

The BLT option requires special, shorter shank adapters. Short flushing head can use female R32 shank adapter.

## BLT OPTION FOR DF540L

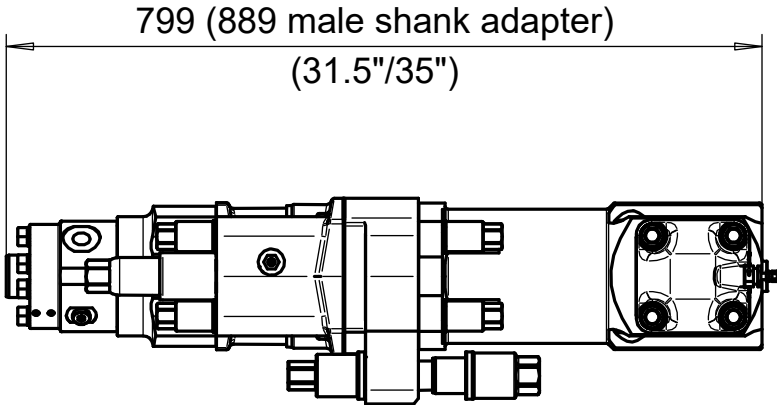

## BLT OPTION FOR DF550L AND DF560L

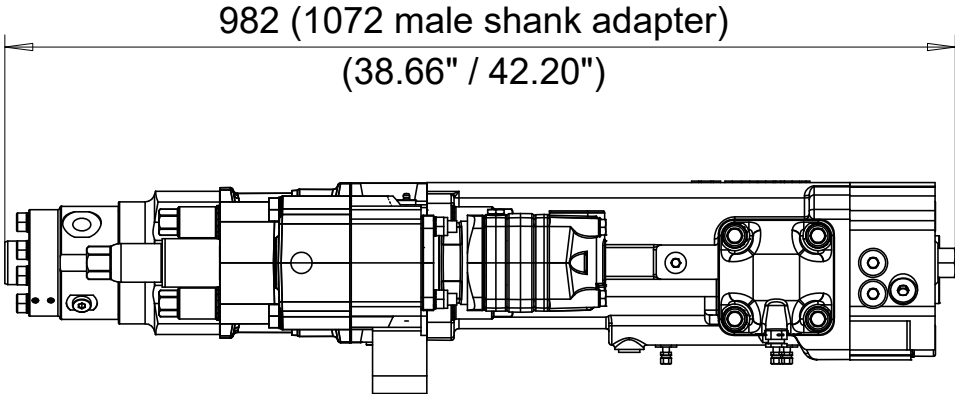

### TECHNICAL SPECIFICATIONS

#### BLT AND BLTG OPTION SHANK ADAPTERS

BLT (SHORT VARIANT)	Male R32, R38, T38 and female R32
BLTG (LONG AND GROUTING VARIANTS)	Male R32, R38, T35, T38 and T45

#### FLUSHING SEALS

STANDARD	3+1
BLT (SHORT VARIANT)	3+2 or 3+1
BLTG (LONG AND GROUTING VARIANTS)	4+2



# BLTG OPTION FOR GROUTING

BLTG has a long flushing head with extra seals and an option to use extra support bearing to protect the flushing seals. This option can also be used for tunnelling and general excavations.

BLTG option can be used with Doofor DF540L, DF550L and DF560L rock drills. It can also be combined with 2M option.

The BLTG option requires special, longer shank adapters.

## BLTG OPTION FOR DOOFOR DF540L

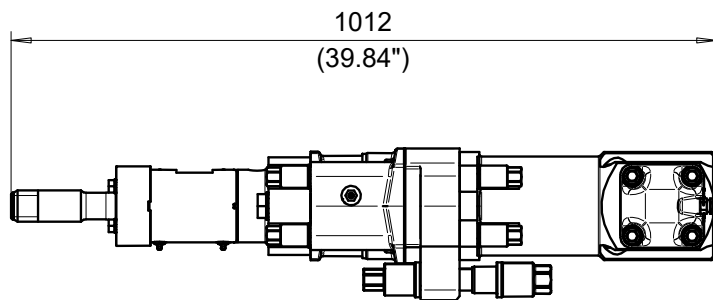

## BLTG OPTION FOR DOOFOR DF550L / DF560L

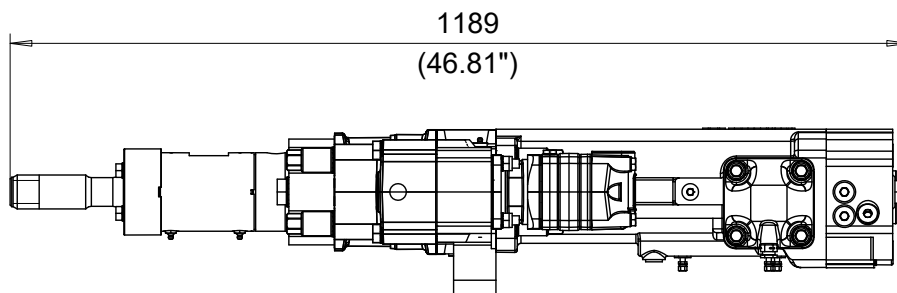

### TECHNICAL SPECIFICATIONS

#### BLT AND BLTG OPTION SHANK ADAPTERS

BLT (SHORT VARIANT)	Male R32, R38, T38 and female R32
BLTG (LONG AND GROUTING VARIANTS)	Male R32, R38, T35, T38 and T45

#### FLUSHING SEALS

STANDARD	3+1
BLT (SHORT VARIANT)	3+2 or 3+1
BLTG (LONG AND GROUTING VARIANTS)	4+2

# COATED SHANK ADAPTERS

Doofor offers coated shank adapters as an alternative for standard, uncoated shank adapter. Coated shank adapters come in variety of different sizes for variety of Doofor Hydraulic Rock drills.

Advanced, durable coating protects the shank adapter from the harmful effects of the corrosive flushing water and extends the usable drilling time for both the flushing seals and the shank adapter.

Combining coated shank adapters together with Doofor's effective drilling technology, easy, affordable and fast maintenance, and advanced options for Doofor rock drills, the drilling becomes cost-effective and sustainable.





# BLTF OPTION FOR GROUTING

BLTF-option replaces the flushing head of the rock drill with a separate flushing box, making it possible to inject grouting material easily. It requires special female R38 shank adapters.

The BLTF-option can be used with Doofor DF540L, DF550L and DF560L rock drills. It can also be used together with 2M-option.

## TECHNICAL SPECIFICATIONS

### BLTF OPTION SHANK ADAPTERS

BLTF	Female T38, R38 and R32. Male shank adapters possible.
------	--

### FLUSHING SEALS

BLTF FLUSHING HEAD	4+1
--------------------	-----

### BLTF OPTION FOR DOOFOR DF540L

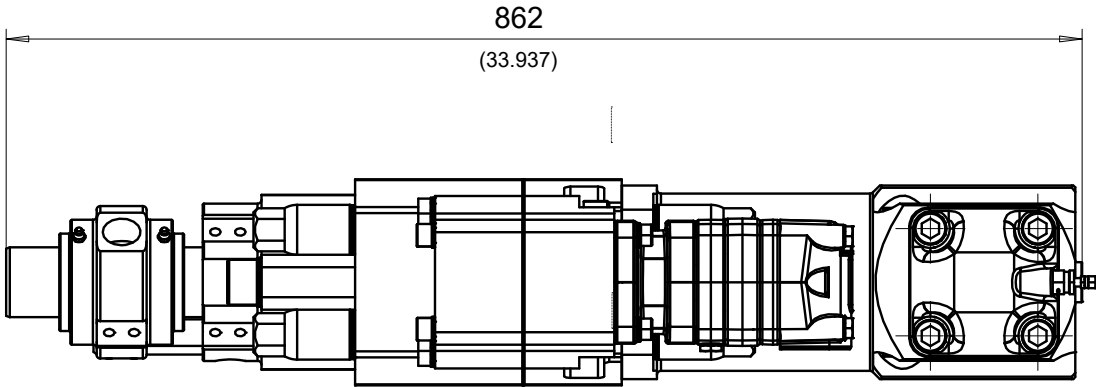

### BLTF OPTION FOR DOOFOR DF550L AND DF560L

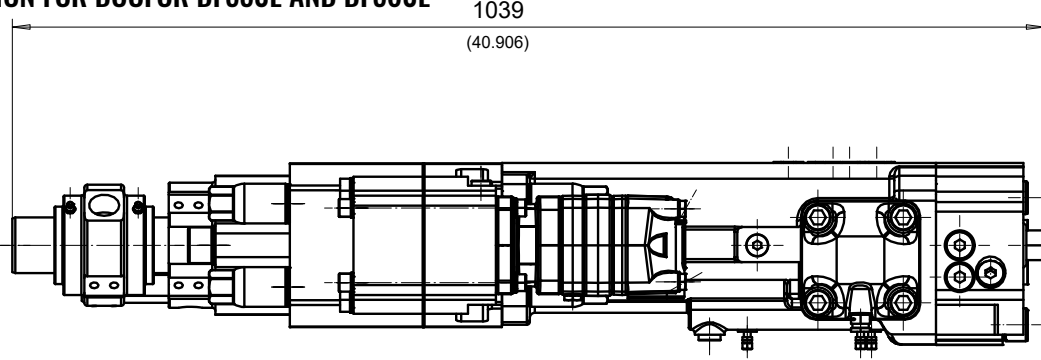

# DOOFOR FEED SYSTEM COMPONENT KIT

Doofor offers a set of supporting components for customers, who wish to build their own drill feed. For example, base machines for the drill feed can be excavators, mini-loaders and skid steer loaders. All components can be purchased separately.



## Robust machined carriage:

Durable machined carriage plates, with chain tensioning mechanism and wear-resistant slide plates.



## Standard option:

Robust chain drive for feed. Motor with brake and counterbalance valve system.

## Alternative option:

Hydraulic rod grabber with opposing cylinders.



## Alternative option:

Manually openable or fixed rod guide in various sizes for your drilling needs.

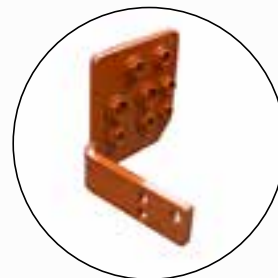

## Extra options:

- Hose bracket
- Lubricator for the rock drill
- Hydraulic air compressor
- Hydraulic, pneumatic and manually operated drill steel retainers for hexagonal drill steels.

Doofor drilling attachment kit is suitable for rock drills under 100 kg (220 lb).





 **Doofor**  
ROCK DRILLS  
**DOOFOR.COM**

KAARNAKATU 11  
FI-37150 NOKIA, **FINLAND**  
TEL. +358 3 343 0747  
INFORMATION@DOOFOR.FI

