

FUDU CMR4 NARROW GAUGE ULP FACE DRILL

CMR4 ULP SERIES CRAWLER RIG FACE DRILL

APPLICATION

Face drilling (hard rock)
Rotary drilling (conventional drill & blast - soft rock <80 MPa)

FEATURES

Remote control
Excellent stability & maneuverability (track driven, skid steer)
360-degree drill mast rotation
Narrow gauge for easy access to tight areas
Doofer DF530XS high efficiency rock drill
Optional rotation drill head (S3 rotation unit)*
Robust, easy to operate and maintain
380VAC/525VAC/1000VAC or dual voltage 525/1000VAC

SPECIFICATIONS

Transport Height	690 mm
Width	1,626 mm
Tramming Length	3,945 mm
Max Ground Clearance	250 mm
Weight	4,000 kg ref.
Stability (incline & cross grade)	12.5 degrees
Max tramming speed	1.5 kph
Electric Motor	22 kW, 525/1000 VAC
Hydraulic System	
- Max Pressure	210 Bar
- Max Flow	90 lpm
- Tank Capacity	70 lt

Drill Mast	CFP180 Feed Frame
Feed Frame Length	3,132 mm
Max Horizontal Drill Height	1,700 mm
Min Seam Height	800 mm
Max Drill Travel	1,800 mm
Max Feed Thrust	450 kg.f
Hydraulic Drifter (Hardrock)	Doofer DF530XS
Power	10 kW
Max Torque	175 Nm
Max Speed	250 rpm
Chuck Size	R32
Max Water Pressure (flushing)	10 Bar
Min Water Pressure (flushing)	5 Bar
Rotary Drill* (Softrock)	S3
Max Torque	375 Nm
Max Speed	600 rpm
Chuck Size	22 mm Hex

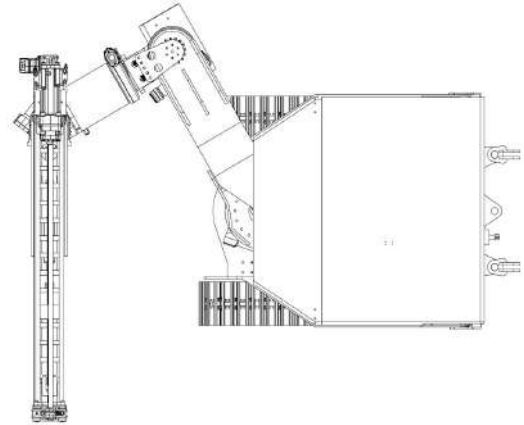
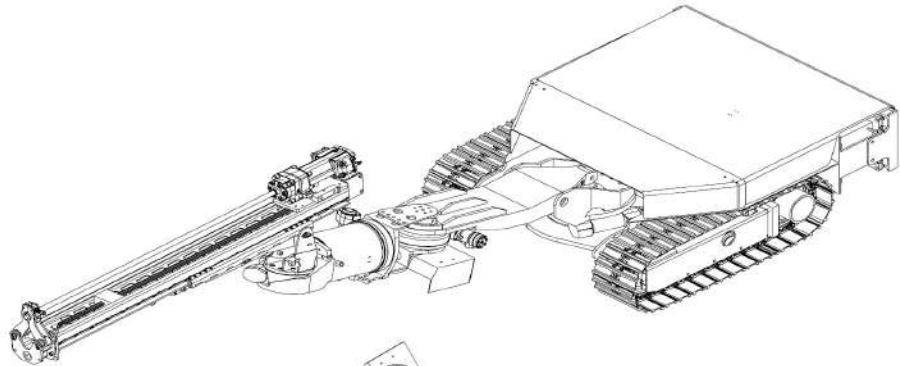

Drill Coverage

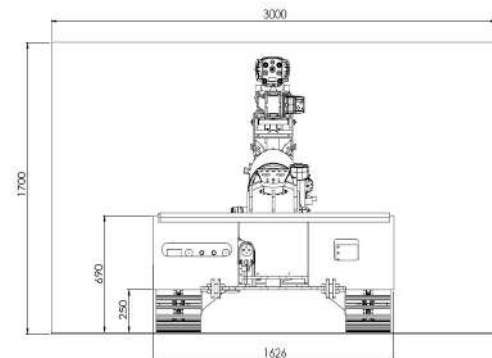

SAFETY

Diagnostics mode on the remote control
Prestart warning siren
Tramming alarm
Fire extinguisher
Multi e-stops around unit
Optional PDS ready to mine specification

DOCUMENTATION

Operator & technician manual
Risk assessment

